



TRAFFIC CRASH REPORT

LOCAL REPORT NUMBER *	CRASH SEVERITY	HIT/SKIP
17 MPD 0450	3 1 - FATAL 2 - INJURY 3 - PDO	<input type="checkbox"/> 1 - SOLVED <input type="checkbox"/> 2 - UNSOLVED

LOCAL INFORMATION	REPORTING AGENCY NCIC *	REPORTING AGENCY NAME *	NUMBER OF UNITS	UNIT IN ERROR
17MPD0450	03801	Millersburg Police Department	1	1 98 - ANIMAL 99 - UNKNOWN

COUNTY *	CITY *	CITY, VILLAGE, TOWNSHIP *	CRASH DATE *	TIME OF CRASH	DAY OF WEEK
Holmes	<input type="checkbox"/> CITY * <input checked="" type="checkbox"/> VILLAGE * <input type="checkbox"/> TOWNSHIP *	Millersburg	03/14/2017	1445	Tue

DEGREES/MINUTES/SECONDS	DECIMAL DEGREES
LATITUDE 40:33:21.87	LONGITUDE 81:55:05.40

ROADWAY DIVISION	DIVIDED LANE DIRECTION OF TRAVEL	NUMBER OF THRU LANES	ROAD TYPES OR MILEPOST
<input type="checkbox"/> DIVIDED <input checked="" type="checkbox"/> UNDIVIDED	<input type="checkbox"/> N - NORTHBOUND <input type="checkbox"/> S - SOUTHBOUND <input type="checkbox"/> E - EASTBOUND <input type="checkbox"/> W - WESTBOUND	1	AL - ALLEY CR - CIRCLE HE - HEIGHTS MP - MILEPOST PL - PLACE ST - STREET WA - WAY AV - AVENUE CT - COURT HW - HIGHWAY PK - PARKWAY RD - ROAD TE - TERRACE BL - BOULEVARD DR - DRIVE LA - LANE PI - PIKE SQ - SQUARE TL - TRAIL

LOCATION ROUTE NUMBER	LOC PREFIX	LOCATION ROAD NAME	LOCATION ROUTE TYPE	ROUTE TYPES
	N, S, E, W	Private Property	DR	IR - INTERSTATE ROUTE (INC. TURNPIKE) US - US ROUTE CR - NUMBERED COUNTY ROUTE SR - STATE ROUTE TR - NUMBERED TOWNSHIP ROUTE

DISTANCE FROM REFERENCE	DIR FROM REF	REFERENCE ROUTE	REFERENCE ROUTE NUMBER	REF PREFIX	REFERENCE NAME (ROAD, MILEPOST, HOUSE #)	REFERENCE ROAD TYPE
AT <input type="checkbox"/> MILES <input type="checkbox"/> FEET <input type="checkbox"/> YARDS	<input type="checkbox"/> N, S, E, W			N, S, E, W	181 N Washington Street	

REFERENCE POINT USED	CRASH LOCATION	LOCATION OF FIRST HARMFUL EVENT
3 1 - INTERSECTION 2 - MILE POST 3 - HOUSE NUMBER	01 01 - NOT AN INTERSECTION 02 - FOUR-WAY INTERSECTION 03 - T-INTERSECTION 04 - Y-INTERSECTION 05 - TRAFFIC CIRCLE/ ROUNDABOUT 06 - FIVE-POINT, OR MORE 07 - ON RAMP 08 - OFF RAMP 09 - CROSSOVER 10 - DRIVEWAY/ ALLEY ACCESS	1 1 - ON ROADWAY 2 - ON SHOULDER 3 - IN MEDIAN 4 - ON ROADSIDE 5 - ON GORE 6 - OUTSIDE TRAFFICWAY 9 - UNKNOWN

ROAD CONTOUR	ROAD CONDITIONS	WEATHER
1 1 - STRAIGHT LEVEL 2 - STRAIGHT GRADE 3 - CURVE LEVEL 4 - CURVE GRADE 9 - UNKNOWN	01 PRIMARY SECONDARY	2 1 - CLEAR 2 - CLOUDY 3 - FOG, SMOG, SMOKE 4 - RAIN 5 - SLEET, HAIL 6 - SNOW 7 - SEVERE CROSSWINDS 8 - BLOWING SAND, SOIL, DIRT, SNOW 9 - OTHER/ UNKNOWN

MANNER OF CRASH COLLISION/IMPACT	WEATHER
1 1 - NOT COLLISION BETWEEN TWO MOTOR VEHICLES IN TRANSPORT 2 - REAR-END 3 - HEAD-ON 4 - REAR-TO-REAR 5 - BACKING 6 - ANGLE 7 - SIDESWIPE, SAME DIRECTION 8 - SIDESWIPE, OPPOSITE DIRECTION 9 - UNKNOWN	2 1 - CLEAR 2 - CLOUDY 3 - FOG, SMOG, SMOKE 4 - RAIN 5 - SLEET, HAIL 6 - SNOW 7 - SEVERE CROSSWINDS 8 - BLOWING SAND, SOIL, DIRT, SNOW 9 - OTHER/ UNKNOWN

ROAD SURFACE	LIGHT CONDITIONS	SCHOOL BUS RELATED
1 1 - CONCRETE 2 - BLACKTOP 3 - BITUMINOUS, ASPHALT 4 - SLAG, GRAVEL, STONE 5 - DIRT 6 - OTHER	1 PRIMARY SECONDARY 1 - DAYLIGHT 2 - DAWN 3 - DUSK 4 - DARK - LIGHTED ROADWAY 5 - DARK - ROADWAY NOT LIGHTED 6 - DARK - UNKNOWN ROADWAY LIGHTING 7 - GLARE 8 - OTHER	<input type="checkbox"/> SCHOOL BUS RELATED <input type="checkbox"/> YES, SCHOOL BUS DIRECTLY INVOLVED <input type="checkbox"/> YES, SCHOOL BUS INDIRECTLY INVOLVED

WORK ZONE RELATED	TYPE OF WORK ZONE	LOCATION OF CRASH IN WORK ZONE
<input type="checkbox"/> WORKERS PRESENT <input type="checkbox"/> LAW ENFORCEMENT PRESENT (OFFICER/VEHICLE) <input type="checkbox"/> LAW ENFORCEMENT PRESENT (VEHICLE ONLY)	1 1 - LANE CLOSURE 2 - LANE SHIFT/ CROSSOVER 3 - WORK ON SHOULDER OR MEDIAN 4 - INTERMITTENT OR MOVING WORK 5 - OTHER	1 1 - BEFORE THE FIRST WORK ZONE WARNING SIGN 2 - ADVANCE WARNING AREA 3 - TRANSITION AREA 4 - ACTIVITY AREA 5 - TERMINATION AREA

NARRATIVE
Unit number one was leaving the Killbuck Savings Banks drive thru when the extended utility box on unit number one struck the drive thru's deposit box and tube.

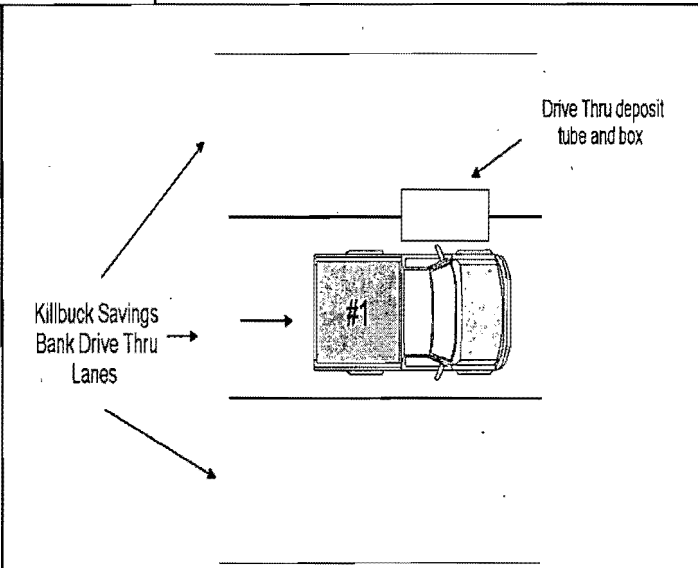

REPORT TAKEN BY	<input type="checkbox"/> SUPPLEMENT (CORRECTION OR ADDITION TO AN EXISTING REPORT SENT TO ODPDS)					
<input checked="" type="checkbox"/> POLICE AGENCY <input type="checkbox"/> MOTORIST						
DATE CRASH REPORTED	TIME CRASH REPORTED	DISPATCH TIME	ARRIVAL TIME	TIME CLEARED	OTHER INVESTIGATION TIME	TOTAL MINUTES
03/14/2017	1513	1513	1515	1531	45	63
OFFICER'S NAME	OFFICER'S BADGE NUMBER	CHECKED BY				
Herman, Kim	101					



UNIT

LOCAL REPORT NUMBER

17 MPD 0450

UNIT NUMBER 1	OWNER NAME: LAST, FIRST, MIDDLE (<input type="checkbox"/> SAME AS DRIVER) D & D Builders, ,	OWNER PHONE NUMBER 330-674-2524	DAMAGE SCALE 2	DAMAGE AREA FRONT REAR
OWNER ADDRESS: CITY, STATE, ZIP (<input type="checkbox"/> SAME AS DRIVER) 7391 CR 203, Millersburg, OH, 44654			1 - NONE	
LP STATE OH	LICENSE PLATE NUMBER PJQ4496	VEHICLE IDENTIFICATION NUMBER 1GCJK33D37F137990	2 - MINOR	
VEHICLE YEAR 2007	VEHICLE MAKE Chevrolet	VEHICLE MODEL Silverado	3 - FUNCTIONAL	
VEHICLE COLOR WHI	INSURANCE COMPANY Farmers	POLICY NUMBER 60543-49-86	4 - DISABLING	
PROOF OF INSURANCE SHOWN	TOWED BY		9 - UNKNOWN	
CARRIER NAME, ADDRESS, CITY, STATE, ZIP				CARRIER PHONE

US DOT	VEHICLE WEIGHT GVWR/GCWR <input type="checkbox"/> 1 - LESS THAN OR EQUAL TO 10K LBS <input type="checkbox"/> 2 - 10,001 TO 26,000K LBS <input type="checkbox"/> 3 - MORE THAN 26,000K LBS	CARGO BODY TYPE 01 - NO CARGO BODY TYPE/NOT APPLICABLE 02 - BUS/VAN (9-15 SEATS, INC DRIVER) 03 - BUS (16+ SEATS, INC DRIVER) 04 - VEHICLE TOWING ANOTHER VEHICLE 05 - LOGGING 06 - INTERMODAL CONTAINER CHASSIS 07 - CARGO VAN/ENCLOSED BOX 08 - GRAIN, CHIPS, GRAVEL	09 - POLE 10 - CARGO TANK 11 - FLAT BED 12 - DUMP 13 - CONCRETE MIXER 14 - AUTO TRANSPORTER 15 - GARBAGE/REFUSE 99 - OTHER/UNKNOWN	TRAFFICWAY DESCRIPTION 5 - 1 - T WO-WAY, NOT DIVIDED 2 - T WO-WAY, NOT DIVIDED, CONTINUOUS LEFT TURN LANE 3 - T WO-WAY, DIVIDED, UNPROTECTED (PAINTED OR GRASS 4FT.) MEDIA 4 - T WO-WAY, DIVIDED, POSITIVE MEDIAN BARRIER 5 - ONE-WAY TRAFFICWAY <input type="checkbox"/> HIT / SKIP UNIT
HM PLACARD ID NO.	HAZARDOUS MATERIAL RELATED <input type="checkbox"/>			
HM CLASS NUMBER				

NON-MOTORIST LOCATION PRIOR TO IMPACT <input type="checkbox"/>	TYPE OF USE 1 - PERSONAL 2 - COMMERCIAL 3 - GOVERNMENT <input type="checkbox"/> IN EMERGENCY RESPONSE	UNIT TYPE 07 - PASSENGER VEHICLES (LESS THAN 9 PASSENGERS) 01 - SUB-COMPACT 02 - COMPACT 03 - MID SIZE 04 - FULL SIZE 05 - MINIVAN 06 - SPORT UTILITY VEHICLE 07 - PICKUP 08 - VAN 09 - MOTORCYCLE 10 - MOTORIZED BICYCLE 11 - SNOWMOBILE/ATV 12 - OTHER PASSENGER VEHICLE	MED/HEAVY TRUCKS OR COMBO UNITS > 10K LBS BUS/VAN/LMG (9 OR MORE INCLUDING DRIVER) 13 - SINGLE UNIT TRUCK OR VAN 2AXLE, 6 TIRES 14 - SINGLE UNIT TRUCK, 3+ AXLES 15 - SINGLE UNIT TRUCK / TRAILER 16 - TRUCK/TRACTOR (BOBTAIL) 17 - TRACTOR/SEMI-TRAILER 18 - TRACTOR/DOUBLE 19 - TRACTOR/TRIPLES 20 - OTHER MED/HEAVY VEHICLE	NON-MOTORIST 21 - BUS/VAN (9-15 SEATS, INC DRIVER) 22 - BUS (16+ SEATS, INC DRIVER) 23 - ANIMAL WITH RIDER 24 - ANIMAL WITH BUGGY, WAGON, SURREY 25 - BICYCLE/PEDACYCLIST 26 - PEDESTRIAN/SKATER 27 - OTHER NON-MOTORIST
<input type="checkbox"/> HAS HM PLACARD				

SPECIAL FUNCTION 01 - NONE 02 - TAXI 03 - RENTAL TRUCK (OVER 10K LBS) 04 - BUS - SCHOOL (PUBLIC OR PRIVATE) 05 - BUS - TRANSIT 06 - BUS - CHARTER 07 - BUS - SHUTTLE 08 - BUS - OTHER	09 - AMBULANCE 10 - FIRE 11 - HIGHWAY/MAINTENANCE 12 - MILITARY 13 - POLICE 14 - PUBLIC UTILITY 15 - OTHER GOVERNMENT 16 - CONSTRUCTION EQUIP.	17 - FARM VEHICLE 18 - FARM EQUIPMENT 19 - MOTORHOME 20 - GOLF CART 21 - TRAIN 22 - OTHER (EXPLAIN IN NARRATIVE)	MOST DAMAGED AREA 01 - NONE 02 - CENTER FRONT 03 - RIGHT FRONT 04 - RIGHT SIDE 05 - RIGHT REAR 06 - REAR CENTER 07 - LEFT REAR	08 - LEFT SIDE 09 - LEFT FRONT 10 - TOP AND WINDOWS 11 - UNDERCARRIAGE 12 - LOAD/TRAILER 13 - TOTAL (ALL AREAS) 14 - OTHER	99 - UNKNOWN	ACTION 3 - 1 - NON-CONTACT 2 - NON-COLLISION 3 - STRIKING 4 - STRUCK 5 - STRIKING/STRUCK 9 - UNKNOWN
---	---	---	---	--	--------------	--

PRE-CRASH ACTIONS 01 - MOTORIST 02 - STRAIGHT AHEAD 03 - BACKING 04 - CHANGING LANES 05 - OVERTAKING/PASSING 06 - MAKING RIGHT TURN 07 - MAKING LEFT TURN 99 - UNKNOWN	07 - MAKING U-TURN 08 - ENTERING TRAFFIC LANE 09 - LEAVING TRAFFIC LANE 10 - PARKED 11 - SLOWING OR STOPPED IN TRAFFIC 12 - DRIVERLESS	13 - NEGOTIATING A CURVE 14 - OTHER MOTORIST ACTION	NON-MOTORIST 15 - ENTERING OR CROSSING SPECIFIED LOCATION 16 - WALKING, RUNNING, JOGGING, PLAYING, CYCLING 17 - WORKING 18 - PUSHING VEHICLE 19 - APPROACHING OR LEAVING VEHICLE 20 - STANDING 21 - OTHER NON-MOTORIST ACTION
--	---	--	--

CONTRIBUTING CIRCUMSTANCE PRIMARY 17 - 01 - NONE 02 - FAILURE TO YIELD 03 - RAN RED LIGHT 04 - RAN STOP SIGN SECONDARY 05 - EXCEEDED SPEED LIMIT 06 - UNSAFE SPEED 07 - IMPROPER TURN 08 - LEFT OF CENTER 09 - FOLLOWED TOO CLOSELY/ACDA 10 - IMPROPER LANE CHANGE /PASSING/OFF ROAD 99 - UNKNOWN	MOTORIST 01 - NONE 02 - FAILURE TO YIELD 03 - RAN RED LIGHT 04 - RAN STOP SIGN 05 - EXCEEDED SPEED LIMIT 06 - UNSAFE SPEED 07 - IMPROPER TURN 08 - LEFT OF CENTER 09 - FOLLOWED TOO CLOSELY/ACDA 10 - IMPROPER LANE CHANGE /PASSING/OFF ROAD	11 - IMPROPER BACKING 12 - IMPROPER START FROM PARKED POSITION 13 - STOPPED OR PARKED ILLEGALLY 14 - OPERATING VEHICLE IN NEGLIGENT MANNER 15 - SWERING TO AVOID (DUE TO EXTERNAL CONDITIONS) 16 - WRONG SIDE/WRONG WAY 17 - FAILURE TO CONTROL 18 - VISION OBSTRUCTION 19 - OPERATING DEFECTIVE EQUIPMENT 20 - LOAD SHIFTING/FALLING/SPILLING 21 - OTHER IMPROPER ACTION	NON-MOTORIST 22 - NONE 23 - IMPROPER CROSSING 24 - DARTING 25 - LYING AND/OR ILLEGALLY IN ROADWAY 26 - FAILURE TO YIELD RIGHT OF WAY 27 - NOT VISIBLE (DARK CLOTHING) 28 - INATTENTIVE 29 - FAILURE TO OBEY TRAFFIC SIGNS /SIGNALS/OFFICER 30 - WRONG SIDE OF THE ROAD 31 - OTHER NON-MOTORIST ACTION	VEHICLE DEFECTS 01 - TURN SIGNALS 02 - HEAD LAMPS 03 - TAIL LAMPS 04 - BRAKES 05 - STEERING 06 - TIRE BLOWOUT 07 - WORN OR SLICK TIRES 08 - TRAILER EQUIPMENT DEFECTIVE 09 - MOTOR TROUBLE 10 - DISABLED FROM PRIOR ACCIDENT 11 - OTHER DEFECTS
---	---	---	---	--

SEQUENCE OF EVENTS 1 - 41 - FIRST HARMFUL EVENT 2 - <input type="checkbox"/> 3 - <input type="checkbox"/> 4 - <input type="checkbox"/> 5 - <input type="checkbox"/> 6 - <input type="checkbox"/> 99 - UNKNOWN	NON-COLLISION EVENTS 01 - OVERTURN/ROLLOVER 02 - FIRE/EXPLOSION 03 - INVERSION 04 - JACKKNIFE 05 - CARGO/EQUIPMENT LOSS OR SHIFT 06 - EQUIPMENT FAILURE (BLOWN TIRE, BRAKE FAILURE, ETC) 07 - SEPARATION OF UNITS 08 - RAN OFF ROAD RIGHT 09 - RAN OFF ROAD LEFT 10 - CROSS MEDIAN OR SUPPORT 11 - CROSS CENTER LINE OPPOSITE DIRECTION OF TRAVEL 12 - DOWNHILL RUNAWAY 13 - OTHER NON-COLLISION	COLLISION WITH FIXED OBJECT 25 - IMPACT ATTENUATOR/CRASH CUSHION 26 - BRIDGE OVERHEAD STRUCTURE 27 - BRIDGE PIER OR ABUTMENT 28 - BRIDGE PARAPET 29 - BRIDGE RAIL 30 - GUARDRAIL FACE 31 - GUARDRAIL END 32 - PORTABLE BARRIER 33 - MEDIAN CABLE BARRIER 34 - MEDIAN GUARDRAIL BARRIER 35 - MEDIAN CONCRETE BARRIER 36 - MEDIAN OTHER BARRIER 37 - TRAFFIC SIGN POST 38 - OVERHEAD SIGN POST 39 - LIGHT/LUMINARIES SUPPORT 40 - UTILITY POLE 41 - OTHER POST, POLE OR SUPPORT 42 - CULVERT 43 - CURB 44 - DITCH 45 - EMBANKMENT 46 - FENCE 47 - MAILBOX 48 - TREE 49 - FIRE HYDRANT 50 - WORK ZONE MAINTENANCE EQUIPMENT 51 - WALL, BUILDING, TUNNEL 52 - OTHER FIXED OBJECT
--	---	--

UNIT SPEED 2 <input type="checkbox"/> STATED <input checked="" type="checkbox"/> ESTIMATED	POSTED SPEED	TRAFFIC CONTROL 01 - NO CONTROLS 02 - STOP SIGN 03 - YIELD SIGN 04 - TRAFFIC SIGNAL 05 - TRAFFIC FLASHERS 06 - SCHOOL ZONE 07 - RAILROAD CROSSBUCKS 08 - RAILROAD FLASHERS 09 - RAILROAD GATES 10 - CONSTRUCTION BARRICADE 11 - PERSON (FLAGGER, OFFICER) 12 - PAVEMENT MARKINGS 13 - CROSSWALK LINES 14 - WALK/DON'T WALK 15 - OTHER 16 - NOT REPORTED	UNIT DIRECTION FROM 4 TO 3 1 - NORTH 2 - SOUTH 3 - EAST 4 - WEST 5 - NORTHEAST 6 - NORTHWEST 7 - SOUTHEAST 8 - SOUTHWEST 9 - UNKNOWN
---	--------------	---	--



MOTORIST / NON-MOTORIST / OCCUPANT

LOCAL REPORT NUMBER

17 MPD 0450

UNIT NUMBER 1	NAME: LAST, FIRST, MIDDLE White, Jason, C	DATE OF BIRTH 08/18/1972	AGE 44	GENDER <input checked="" type="checkbox"/> M F - FEMALE M - MALE
------------------	--	-----------------------------	-----------	--

ADDRESS, CITY, STATE, ZIP 756 Critchfield Street, Millersburg, OH, 44654	CONTACT PHONE - INCLUDE AREA CODE 330-275-2195
---	---

INJURIES <input checked="" type="checkbox"/>	INJURED TAKEN BY <input checked="" type="checkbox"/>	EMS AGENCY	MEDICAL FACILITY INJURED TAKEN TO	SAFETY EQUIPMENT USED 99	DOT COMPLIANT MOTORCYCLE HELMET <input type="checkbox"/>	SEATING POSITION 01	AIR BAG USAGE <input checked="" type="checkbox"/>	EJECTION <input checked="" type="checkbox"/>	TRAPPED <input checked="" type="checkbox"/>
---	---	------------	-----------------------------------	-----------------------------	---	------------------------	--	---	--

OL STATE OH	OPERATOR LICENSE NUMBER RS296126	OL CLASS 4	No VALID DL <input type="checkbox"/>	M/C END <input type="checkbox"/>	CONDITION 1	ALCOHOL/DRUG SUSPECTED 1	ALCOHOL TEST STATUS 1	ALCOHOL TEST TYPE 1	ALCOHOL TEST VALUE	DRUG TEST STATUS 1	DRUG TEST TYPE 1
----------------	-------------------------------------	---------------	---	-------------------------------------	----------------	-----------------------------	--------------------------	------------------------	--------------------	-----------------------	---------------------

OFFENSE CHARGED (<input type="checkbox"/> LOCAL CODE)	OFFENSE DESCRIPTION	CITATION NUMBER	HANDS FREE DEVICE USED <input type="checkbox"/>	DRIVER DISTRACTED BY <input checked="" type="checkbox"/>
---	---------------------	-----------------	--	---

UNIT NUMBER	NAME: LAST, FIRST, MIDDLE	DATE OF BIRTH	AGE	GENDER <input type="checkbox"/> F - FEMALE M - MALE
-------------	---------------------------	---------------	-----	---

ADDRESS, CITY, STATE, ZIP	CONTACT PHONE - INCLUDE AREA CODE
---------------------------	-----------------------------------

INJURIES <input type="checkbox"/>	INJURED TAKEN BY <input type="checkbox"/>	EMS AGENCY	MEDICAL FACILITY INJURED TAKEN TO	SAFETY EQUIPMENT USED	DOT COMPLIANT MOTORCYCLE HELMET <input type="checkbox"/>	SEATING POSITION	AIR BAG USAGE <input type="checkbox"/>	EJECTION <input type="checkbox"/>	TRAPPED <input type="checkbox"/>
--------------------------------------	--	------------	-----------------------------------	-----------------------	---	------------------	---	--------------------------------------	-------------------------------------

OL STATE	OPERATOR LICENSE NUMBER	OL CLASS	No VALID DL <input type="checkbox"/>	M/C END <input type="checkbox"/>	CONDITION	ALCOHOL/DRUG SUSPECTED	ALCOHOL TEST STATUS	ALCOHOL TEST TYPE	ALCOHOL TEST VALUE	DRUG TEST STATUS	DRUG TEST TYPE
----------	-------------------------	----------	---	-------------------------------------	-----------	------------------------	---------------------	-------------------	--------------------	------------------	----------------

OFFENSE CHARGED (<input type="checkbox"/> LOCAL CODE)	OFFENSE DESCRIPTION	CITATION NUMBER	HANDS FREE DEVICE USED <input type="checkbox"/>	DRIVER DISTRACTED BY <input type="checkbox"/>
---	---------------------	-----------------	--	--

INJURIES 1 - NO INJURY / NONE REPORTED 2 - POSSIBLE 3 - NON-INCAPACITATING 4 - INCAPACITATING 5 - FATAL	INJURED TAKEN BY 1 - NOT TRANSPORTED / TREATED AT SCENE 2 - EMS 3 - POLICE 4 - OTHER 9 - UNKNOWN	SAFETY EQUIPMENT USED 99 - UNKNOWN SAFETY EQUIPMENT	MOTORIST 01 - NONE USED - VEHICLE OCCUPANT 02 - SHOULDER BELT ONLY USED 03 - LAP BELT ONLY USED 04 - SHOULDER AND LAP BELT ONLY USED	NON-MOTORIST 05 - CHILD RESTRAINT SYSTEM-FORWARD FACING 06 - CHILD RESTRAINT SYSTEM-REAR FACING 07 - BOOSTER SEAT 08 - HELMET USED	NON-MOTORIST 09 - NONE USED 10 - HELMET USED 11 - PROTECTIVE PADS USED (ELBOWS, KNEES, ETC.) 12 - REFLECTIVE COATING 13 - LIGHTING 14 - OTHER
--	---	--	--	--	---

SEATING POSITION 01 - FRONT - LEFT SIDE (MOTORCYCLE DRIVER) 02 - FRONT - MIDDLE 03 - FRONT - RIGHT SIDE 04 - SECOND - LEFT SIDE (MOTORCYCLE PASSENGER) 05 - SECOND - MIDDLE 06 - SECOND - RIGHT SIDE	07 - THIRD - LEFT SIDE (MOTORCYCLE SIDE CAR) 08 - THIRD - MIDDLE 09 - THIRD - RIGHT SIDE 10 - SLEEPER SECTION OF CAB (TRUCK) 11 - PASSENGER IN OTHER ENCLOSED CARGO AREA (NON-TRAILING UNIT SUCH AS A BUS, PICKUP WITH CAP)	12 - PASSENGER IN UNENCLOSED CARGO AREA 13 - TRAILING UNIT 14 - RIDING ON VEHICLE EXTERIOR (NON-TRAILING UNIT) 15 - NON-MOTORIST 16 - OTHER 99 - UNKNOWN	AIR BAG USAGE 1 - NOT DEPLOYED 2 - DEPLOYED FRONT 3 - DEPLOYED SIDE 4 - DEPLOYED BOTH FRONT/SIDE 5 - NOT APPLICABLE 9 - DEPLOYMENT UNKNOWN
--	---	---	--

EJECTION 1 - NOT EJECTED 2 - TOTALLY EJECTED 3 - PARTIALLY EJECTED 4 - NOT APPLICABLE	TRAPPED 1 - NOT TRAPPED 2 - EXTRICATED BY MECHANICAL MEANS 3 - EXTRICATED BY NON-MECHANICAL MEANS	OPERATOR LICENSE CLASS 1 - CLASS A 2 - CLASS B 3 - CLASS C 4 - REGULAR CLASS (0-10 IS 10) 5 - MC/MOPED ONLY	CONDITION 1 - APPARENTLY NORMAL 2 - PHYSICAL IMPAIRMENT 3 - EMOTIONAL (DEPRESSED, ANGRY, DISTURBE) 4 - ILLNESS	ALCOHOL/DRUG SUSPECTED 5 - FELL ASLEEP, FAINTED, FATIGUE 6 - UNDER THE INFLUENCE OF MEDICATIONS, DRUGS, ALCOHOL 7 - OTHER	ALCOHOL/DRUG SUSPECTED 1 - NONE 2 - YES - ALCOHOL SUSPECTED 3 - YES - HBD NOT IMPAIRED 4 - YES - DRUGS SUSPECTED 5 - YES - ALCOHOL AND DRUGS SUSPECTED
---	--	--	--	--	---

ALCOHOL TEST STATUS 1 - NONE GIVEN 2 - TEST REFUSED 3 - TEST GIVEN, CONTAMINATED SAMPLE/UNUSABLE 4 - TEST GIVEN, RESULTS KNOWN 5 - TEST GIVEN, RESULTS UNKNOWN	ALCOHOL TEST TYPE 1 - NONE 2 - BLOOD 3 - URINE 4 - BREATH 5 - OTHER	DRUG TEST STATUS 1 - NONE GIVEN 2 - TEST REFUSED 3 - TEST GIVEN, CONTAMINATED SAMPLE/UNUSABLE 4 - TEST GIVEN, RESULTS KNOWN 5 - TEST GIVEN, RESULTS UNKNOWN	DRUG TEST TYPE 1 - NONE 2 - BLOOD 3 - URINE 4 - OTHER	DRIVER DISTRACTED BY 1 - NO DISTRACTION REPORTED 2 - PHONE 3 - TEXTING/EMAILING 4 - ELECTRONIC COMMUNICATION DEVICE 5 - OTHER ELECTRONIC DEVICE (NAVIGATION DEVICE, RADIO, DVD)	6 - OTHER INSIDE THE VEHICLE 7 - EXTERNAL DISTRACTION
---	--	--	---	--	--

UNIT NUMBER	NAME: LAST, FIRST, MIDDLE	DATE OF BIRTH	AGE	GENDER <input type="checkbox"/> F - FEMALE M - MALE
-------------	---------------------------	---------------	-----	---

ADDRESS, CITY, STATE, ZIP	CONTACT PHONE - INCLUDE AREA CODE
---------------------------	-----------------------------------

INJURIES <input type="checkbox"/>	INJURED TAKEN BY <input type="checkbox"/>	EMS AGENCY	MEDICAL FACILITY INJURED TAKEN TO	SAFETY EQUIPMENT USED	DOT COMPLIANT MOTORCYCLE HELMET <input type="checkbox"/>	SEATING POSITION	AIR BAG USAGE <input type="checkbox"/>	EJECTION <input type="checkbox"/>	TRAPPED <input type="checkbox"/>
--------------------------------------	--	------------	-----------------------------------	-----------------------	---	------------------	---	--------------------------------------	-------------------------------------

UNIT NUMBER	NAME: LAST, FIRST, MIDDLE	DATE OF BIRTH	AGE	GENDER <input type="checkbox"/> F - FEMALE M - MALE
-------------	---------------------------	---------------	-----	---

ADDRESS, CITY, STATE, ZIP	CONTACT PHONE - INCLUDE AREA CODE
---------------------------	-----------------------------------

INJURIES <input type="checkbox"/>	INJURED TAKEN BY <input type="checkbox"/>	EMS AGENCY	MEDICAL FACILITY INJURED TAKEN TO	SAFETY EQUIPMENT USED	DOT COMPLIANT MOTORCYCLE HELMET <input type="checkbox"/>	SEATING POSITION	AIR BAG USAGE <input type="checkbox"/>	EJECTION <input type="checkbox"/>	TRAPPED <input type="checkbox"/>
--------------------------------------	--	------------	-----------------------------------	-----------------------	---	------------------	---	--------------------------------------	-------------------------------------

MOTORIST/NON-MOTORIST

MOTORIST/NON-MOTORIST

OCCUPANT

OCCUPANT